

Kerto® LVL



Kerto® LVL beams are suitable for use as load-bearing structures in buildings with timber, steel or a concrete frame. These beams are used as supporting beams in ground floor, intermediate floor, and roof structures.

The dimensionally accurate Kerto beam structure supports and gives form to roofs of various shapes. Kerto LVL products combine excellent technical performance with ease of use. The essential qualities of Kerto LVL include strength, dimensional stability and light weight. Kerto also offers architectural elegance in open and visible roof structures.

With Kerto LVL S-beams, it is easy to build high and spacious rooms, large windows, oriels, galleries, and balconies. S-beam has excellent strength-to-weight ratio which allows long spans with minimal deflection. The use of S-beams ensure material efficiency with customised product dimension. The thickness-to-height ratio of S-beams can generally be maximum 1/8.

Kerto LVL Qp-beam is a stiff, rigid and precise roof beam with excellent strength-to-weight ratio. The use of the high and slender beams reduces the need of support grids enabling the construction of spacious rooms and increases the space for insulation. The increase in insulation spaces enables energy efficient structures. The cross-bonded veneer layers minimize swelling, cupping and other dimensional changes of the product. Qp-beam can be manufactured with a higher thickness-to-height ratio than Kerto S-beam, the ratio can be up to 1/12.

The advantages of Kerto beams

- Strong and rigid
- Excellent strength-to-weight ratio
- Energy efficient structures due to slender beams
- Long spans with minimal deflection
- Dimensional stability improved against warp and twist
- Great workability and quick installation time
- Easy to fasten, staple, screw, nail and drill using conventional woodworking tools
- Ensures material efficiency with customised product dimensions
- Long beams, well suited to headers and multi-span purlins
- Extensive range of steel joint parts available on markets
- Easy to design with free Finnwood® design software

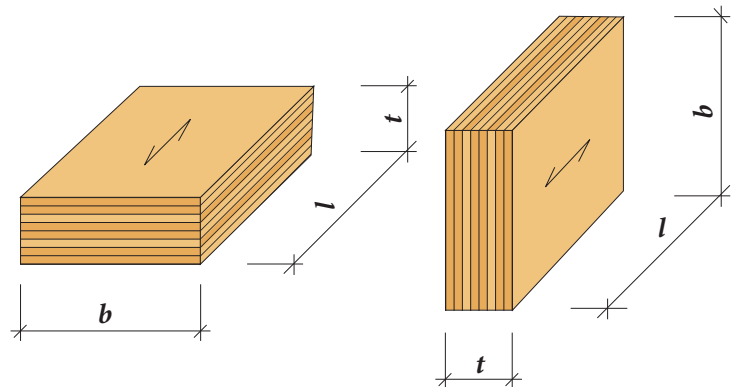

Figure 1. Dimensions of Kerto LVL: b = width (height), l = length, t = thickness. Arrow shows the grain direction of the surface veneer.

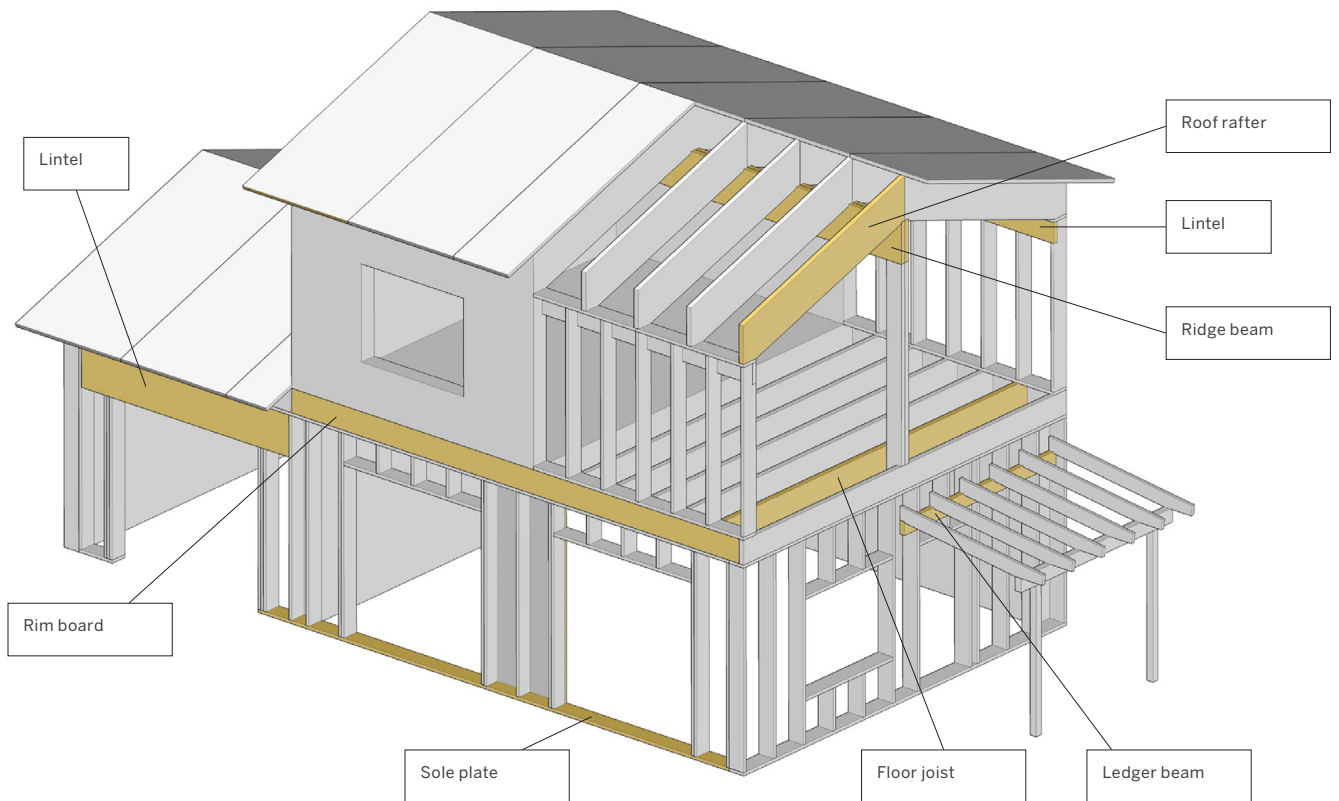

Figure 2. Kerto beam applications in residential building.

Structural design

All Kerto products can be designed according to EN 1995 (Eurocode 5) and its national annexes.

Metsä Wood has developed a special software application, Finnwood®, for structural designers. Individual structures made of Kerto LVL and other Metsä Wood products can be designed and optimised with the software. The user-friendly interface makes designing structural members such as floor joists and roof beams fast and effective.

Benefits offered by Finnwood include an intuitive user interface and easy and fast dimensioning of structural elements according to EC 5. As a result, user obtains clear structural calculations.

Finnwood is available for download free of charge from country websites of Metsä Wood. Registration is required before downloading. Several country specified versions are available including eg. Finland, Sweden, France, Germany and UK.
www.metsawood.com/finnwood

Metsä Wood has also published span tables for Kerto LVL beams and floor joists to help designers to work faster and more efficiently. The tables are available on Metsä Wood website and they include the most common measurements according to local requirements.

This document is property of Metsäliitto Cooperative (Metsä Wood) and is only applicable when used along with products produced by Metsä Wood. Use of the document for other manufacturer's product is prohibited. Metsäliitto Cooperative is not responsible for application of documents or possible faults in documents. This clause must not be removed. Metsä Wood and Kerto are registered trademarks of Metsäliitto Cooperative (Metsä Wood).